

AWK-1131A Series

Entry-level industrial IEEE 802.11a/b/g/n wireless AP/client



Features and Benefits

- IEEE 802.11a/b/g/n AP/client support
- Millisecond-level Client-based Turbo Roaming¹
- Integrated antenna and power isolation
- 5 GHz DFS channel support

Certifications



Introduction

The AWK-1131A industrial wireless AP/client meets the growing need for faster data transmission speeds by supporting IEEE 802.11n technology with a net data rate of up to 300 Mbps. The AWK-1131A is compliant with industrial standards and approvals covering operating temperature, power input voltage, surge, ESD, and vibration. The two redundant DC power inputs increase the reliability of the power supply. The AWK-1131A can operate on either the 2.4 or 5 GHz bands and is backwards-compatible with existing 802.11a/b/g deployments to future-proof your wireless investments.

Improved Higher Data Rate and Channel Capacity

- High-speed wireless connectivity with up to 300 Mbps data rate
- MIMO technology to improve the capability of transmitting and receiving multiple data streams
- Increased channel width with channel bonding technology
- Supports flexible channel selection to build up wireless communication system with DFS

Specifications for Industrial-Grade Applications

- Redundant DC power inputs
- Integrated isolation design with enhanced protection against environmental interference
- Compact aluminum housing, IP30-rated

Specifications

WLAN Interface

| | |
|---|---|
| WLAN Standards | 802.11a/b/g/n 802.11i Wireless Security |
| Modulation Type | DSSS MIMO-OFDM OFDM |
| Frequency Band for US (20 MHz operating channels) | 2.412 to 2.462 GHz (11 channels) 5.180 to 5.240 GHz (4 channels) 5.260 to 5.320 GHz (4 channels) ² 5.500 to 5.700 GHz (11 channels) ² 5.745 to 5.825 GHz (5 channels) |
| Frequency Band for EU (20 MHz operating channels) | 2.412 to 2.472 GHz (13 channels) 5.180 to 5.240 GHz (4 channels) |

1. The Turbo Roaming recovery time indicated herein is an average of test results documented, in optimized conditions, across APs configured with interference-free 20-MHz RF channels, WPA2-PSK security, and default Turbo Roaming parameters. The clients are configured with 3-channel roaming at 100 Kbps traffic load. Other conditions may also impact roaming performance. For more information about Turbo Roaming parameter settings, refer to the product manual.
2. DFS (Dynamic Frequency Selection) channel support: In AP mode, when a radar signal is detected, the device will automatically switch to another channel. However, according to regulations, after switching channels, a 60-second availability check period is required before starting the service.

| | 5.260 to 5.320 GHz (4 channels) ³ 5.500 to 5.700 GHz (11 channels) ³ | | | | | | | | | | | | | | | | | | | | | | | | |
|---|---|--------|--------|----|----|---------|--------|--------|--------|----------------|--------|--------|--------|----------------|--------|--------|--------|-----------------|--------|--------|--------|----------------|--------|---|---|
| Frequency Band for JP (20 MHz operating channels) | 2.412 to 2.484 GHz (14 channels) 5.180 to 5.240 GHz (4 channels) 5.260 to 5.320 GHz (4 channels) ³ 5.500 to 5.700 GHz (11 channels) ³ | | | | | | | | | | | | | | | | | | | | | | | | |
| Wireless Security | WEP encryption (64-bit and 128-bit) WPA/WPA2-Enterprise (IEEE 802.1X/RADIUS, TKIP, AES) WPA/WPA2-Personal | | | | | | | | | | | | | | | | | | | | | | | | |
| Transmission Rate | 802.11b: 1 to 11 Mbps 802.11a/g: 6 to 54 Mbps 802.11n: 6.5 to 300 Mbps | | | | | | | | | | | | | | | | | | | | | | | | |
| Transmitter Power for 802.11a | 23±1.5 dBm @ 6 to 24 Mbps 21±1.5 dBm @ 36 Mbps 20±1.5 dBm @ 48 Mbps 18±1.5 dBm @ 54 Mbps | | | | | | | | | | | | | | | | | | | | | | | | |
| Transmitter Power for 802.11b | 26±1.5 dBm @ 1 Mbps 26±1.5 dBm @ 2 Mbps 26±1.5 dBm @ 5.5 Mbps 25±1.5 dBm @ 11 Mbps | | | | | | | | | | | | | | | | | | | | | | | | |
| Transmitter Power for 802.11g | 23±1.5 dBm @ 6 to 24 Mbps 21±1.5 dBm @ 36 Mbps 19±1.5 dBm @ 48 Mbps 18±1.5 dBm @ 54 Mbps | | | | | | | | | | | | | | | | | | | | | | | | |
| Transmitter Power for 802.11n (2.4 GHz) | 23±1.5 dBm @ MCS0/8 20 MHz 18±1.5 dBm @ MCS7/15 20 MHz 23±1.5 dBm @ MCS0/8 40 MHz 17±1.5 dBm @ MCS7/15 40 MHz | | | | | | | | | | | | | | | | | | | | | | | | |
| Transmitter Power for 802.11n (5 GHz) | 23±1.5 dBm @ MCS0/8 20 MHz 18±1.5 dBm @ MCS7/15 20 MHz 23±1.5 dBm @ MCS0/8 40 MHz 17±1.5 dBm @ MCS7/15 40 MHz | | | | | | | | | | | | | | | | | | | | | | | | |
| Transmitter Power | <table border="1"> <thead> <tr> <th></th> <th>US</th> <th>EU</th> <th>JP</th> </tr> </thead> <tbody> <tr> <td>2.4 GHz</td> <td>26 dBm</td> <td>18 dBm</td> <td>18 dBm</td> </tr> <tr> <td>5 GHz (UNII-1)</td> <td>23 dBm</td> <td>21 dBm</td> <td>21 dBm</td> </tr> <tr> <td>5 GHz (UNII-2)</td> <td>23 dBm</td> <td>21 dBm</td> <td>21 dBm</td> </tr> <tr> <td>5 GHz (UNII-2e)</td> <td>23 dBm</td> <td>23 dBm</td> <td>23 dBm</td> </tr> <tr> <td>5 GHz (UNII-3)</td> <td>23 dBm</td> <td>–</td> <td>–</td> </tr> </tbody> </table> <p>Note: Based on regional regulations, the maximum transmission power allowed on the UNII bands is restricted in the firmware, as indicated above.</p> | | US | EU | JP | 2.4 GHz | 26 dBm | 18 dBm | 18 dBm | 5 GHz (UNII-1) | 23 dBm | 21 dBm | 21 dBm | 5 GHz (UNII-2) | 23 dBm | 21 dBm | 21 dBm | 5 GHz (UNII-2e) | 23 dBm | 23 dBm | 23 dBm | 5 GHz (UNII-3) | 23 dBm | – | – |
| | US | EU | JP | | | | | | | | | | | | | | | | | | | | | | |
| 2.4 GHz | 26 dBm | 18 dBm | 18 dBm | | | | | | | | | | | | | | | | | | | | | | |
| 5 GHz (UNII-1) | 23 dBm | 21 dBm | 21 dBm | | | | | | | | | | | | | | | | | | | | | | |
| 5 GHz (UNII-2) | 23 dBm | 21 dBm | 21 dBm | | | | | | | | | | | | | | | | | | | | | | |
| 5 GHz (UNII-2e) | 23 dBm | 23 dBm | 23 dBm | | | | | | | | | | | | | | | | | | | | | | |
| 5 GHz (UNII-3) | 23 dBm | – | – | | | | | | | | | | | | | | | | | | | | | | |
| Receiver Sensitivity for 802.11a | -90 dBm @ 6 Mbps -88 dBm @ 9 Mbps -88 dBm @ 12 Mbps -85 dBm @ 18 Mbps -81 dBm @ 24 Mbps -78 dBm @ 36 Mbps -74 dBm @ 48 Mbps -72 dBm @ 54 Mbps | | | | | | | | | | | | | | | | | | | | | | | | |
| Receiver Sensitivity for 802.11b | -93 dBm @ 1 Mbps -93 dBm @ 2 Mbps -93 dBm @ 5.5 Mbps | | | | | | | | | | | | | | | | | | | | | | | | |

3. DFS (Dynamic Frequency Selection) channel support: In AP mode, when a radar signal is detected, the device will automatically switch to another channel. However, according to regulations, after switching channels, a 60-second availability check period is required before starting the service.

| | |
|--|--|
| | -88 dBm @ 11 Mbps |
| Receiver Sensitivity for 802.11g | -88 dBm @ 6 Mbps -86 dBm @ 9 Mbps -85 dBm @ 12 Mbps -85 dBm @ 18 Mbps -85 dBm @ 24 Mbps -82 dBm @ 36 Mbps -78 dBm @ 48 Mbps -74 dBm @ 54 Mbps |
| Receiver Sensitivity for 802.11n (2.4 GHz) | -70 dBm @ MCS7 20 MHz -69 dBm @ MCS15 20 MHz -67 dBm @ MCS7 40 MHz -67 dBm @ MCS15 40 MHz |
| Receiver Sensitivity for 802.11n (5 GHz) | -69 dBm @ MCS7 20 MHz -71 dBm @ MCS15 20 MHz -63 dBm @ MCS7 40 MHz -68 dBm @ MCS15 40 MHz |
| WLAN Operation Mode | Access point, Client, Sniffer |
| Antenna | External, 2/2 dBi, Omni-directional |
| Antenna Connectors | 2 RP-SMA female |
| Ethernet Interface | |
| 10/100/1000BaseT(X) Ports (RJ45 connector) | 1 |
| Standards | IEEE 802.1X for authentication IEEE 802.3 for 10BaseT IEEE 802.3ab for 1000BaseT(X) IEEE 802.3u for 100BaseT(X) |
| Ethernet Software Features | |
| Management | DHCP Server/Client, DNS, HTTP, IPv4, LLDP, Proxy ARP, SMTP, SNMPv1/v2c/v3, Syslog, TCP/IP, Telnet, UDP, Wireless Search Utility, VLAN, MXview, MXconfig |
| Security | HTTPS/SSL, RADIUS, SSH |
| Time Management | SNTP Client |
| Firewall | |
| Filter | ICMP, MAC address, IP protocol, Port-based |
| Serial Interface | |
| Console Port | RS-232, 8-pin RJ45 |
| LED Interface | |
| LED Indicators | PWR, FAULT, STATE, SIGNAL, WLAN, LAN |
| Input/Output Interface | |
| Buttons | Reset button |
| Physical Characteristics | |
| Housing | Metal |
| IP Rating | IP30 |
| Dimensions | 58 x 115 x 70 mm (2.29 x 4.53 x 2.76 in) |

| | |
|--|---|
| Weight | 307 g (0.68 lb) |
| Installation | DIN-rail mounting, Wall mounting (with optional kit) |
| Power Parameters | |
| Input Current | 0.56 A @ 12 VDC, 0.14 A @ 48 VDC |
| Input Voltage | 12 to 48 VDC |
| Power Connector | 1 removable 4-contact terminal block(s) |
| Power Consumption | 6.96 W (max.) |
| Reverse Polarity Protection | Supported |
| Environmental Limits | |
| Operating Temperature | Standard Models: 0 to 60°C (32 to 140°F) Wide Temp. Models: -40 to 75°C (-40 to 167°F) |
| Storage Temperature (package included) | -40 to 85°C (-40 to 185°F) |
| Ambient Relative Humidity | 5 to 95% (non-condensing) |
| Standards and Certifications | |
| EMC | EN 55032/24 |
| EMI | CISPR 32, FCC Part 15B Class B |
| EMS | IEC 61000-4-2 ESD: Contact: 4 kV; Air: 8 kV IEC 61000-4-3 RS: 80 MHz to 1 GHz: 10 V/m IEC 61000-4-4 EFT: Power: 2 kV; Signal: 1 kV IEC 61000-4-5 Surge: Power: 2 kV; Signal: 1 kV IEC 61000-4-6 CS: 3 V IEC 61000-4-8 PFMF |
| Radio | ANATEL, EN 300 328, EN 301 489-1/17, EN 301 893, FCC ID SLE-WAPN008, MIC, NCC, RCM, SRRC, WPC, KC, RCM |
| Safety | EN 60950-1, UL 60950-1 |
| Vibration | IEC 60068-2-6 |
| MTBF | |
| Time | 749,476 hrs |
| Standards | Telcordia SR332 |
| Warranty | |
| Warranty Period | 5 years |
| Details | See www.moxa.com/warranty |
| Package Contents | |
| Device | 1 x AWK-1131 Series wireless AP/client |
| Installation Kit | 1 x cap, plastic, for RJ45 port 1 x DIN-rail kit |
| Antenna | 2 x 2.4/5 GHz antenna |
| Documentation | 1 x quick installation guide 1 x warranty card |

Dimensions

Unit: mm (inch)

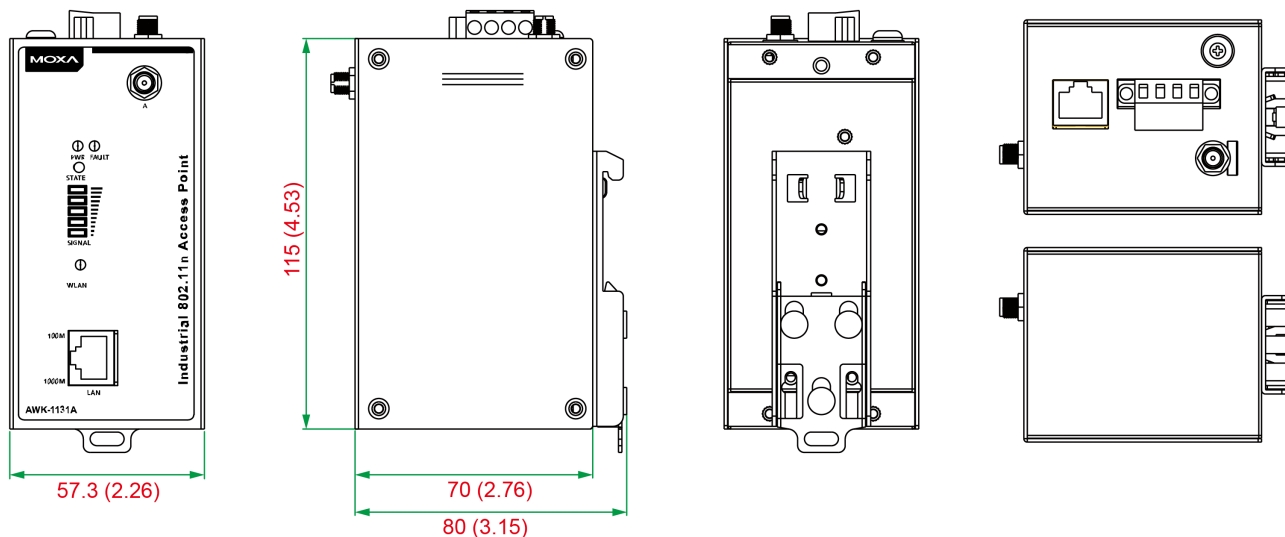

Front View

Side View

Rear View

Top and Bottom Views

Ordering Information

| Model Name | Band | Standards | Operating Temp. |
|----------------|------|---------------|-----------------|
| AWK-1131A-EU | EU | 802.11a/b/g/n | 0 to 60°C |
| AWK-1131A-EU-T | EU | 802.11a/b/g/n | -40 to 75°C |
| AWK-1131A-JP | JP | 802.11a/b/g/n | 0 to 60°C |
| AWK-1131A-JP-T | JP | 802.11a/b/g/n | -40 to 75°C |
| AWK-1131A-US | US | 802.11a/b/g/n | 0 to 60°C |
| AWK-1131A-US-T | US | 802.11a/b/g/n | -40 to 75°C |

Accessories (sold separately)

Antennas

| | |
|-------------------------|--|
| ANT-WDB-ANF-0407 | 2.4/5 GHz, omni-directional antenna, 4/7 dBi, N-type (male) |
| ANT-WDB-ANF-0609 | 2.4/5 GHz, omni-directional antenna, 6/9 dBi, N-type (female) |
| ANT-WDB-ANM-0306 | 2.4/5 GHz, omni-directional antenna, 3/6 dBi, N-type (male) |
| ANT-WDB-ANM-0407 | 2.4/5 GHz, dual-band omni-directional antenna, 4/7 dBi, N-type (male) |
| ANT-WDB-ANM-0502 | 2.4/5 GHz, omni-directional antenna, 5/2 dBi, N-type (male) |
| ANT-WDB-ANM-0609 | 2.4/5 GHz, omni-directional antenna, 6/9 dBi, N-type (male) |
| ANT-WDB-ARM-02 | 2.4/5 GHz, omni-directional rubber duck antenna, 2 dBi, RP-SMA (male) |
| ANT-WDB-ARM-0202 | 2.4/5 GHz, panel antenna, 2/2 dBi, RP-SMA (male) |
| ANT-WDB-PNF-1518 | 2.4/5 GHz, panel antenna, 15/18 dBi, N-type (female) |
| MAT-WDB-CA-RM-2-0205 | 2.4/5 GHz, ceiling antenna, 2/5 dBi, MIMO 2x2, RP-SMA-type (male) |
| MAT-WDB-DA-RM-2-0203-1m | 2.4/5 GHz, desktop antenna, 2/3 dBi, MIMO 2x2, RP-SMA-type (male), 1 m cable |
| MAT-WDB-PA-NF-2-0708 | 2.4/5 GHz, panel antenna, 7/8 dBi, MIMO 2x2, N-type (female) |
| ANT-WSB5-ANF-12 | 5 GHz, omni-directional antenna, 12 dBi, N-type (female) |
| ANT-WSB5-PNF-18 | 5 GHz, directional panel antenna, 18 dBi, N-type (female) |
| ANT-WSB-ANF-09 | 2.4 GHz, omni-directional antenna, 9 dBi, N-type (female) |

| | |
|----------------------|---|
| ANT-WSB-PNF-12 | 2.4 GHz, directional panel antenna, 12dBi, N-type (female) |
| ANT-WSB-PNF-18 | 2.4 GHz, directional panel antenna, 18 dBi, N-type (female) |
| ANT-WSB-AHRM-05-1.5m | 2.4 GHz, omni-directional/dipole antenna, 5 dBi, RP-SMA (male), 1.5 m cable |

Wireless Adapters

| | |
|-------------------------|---|
| A-ADP-RJ458P-DB9F-ABC01 | DB9 female to RJ45 connector for the ABC-01 |
|-------------------------|---|

Wireless Antenna Cables

| | |
|-------------------|--|
| A-CRF-RFRM-R4-150 | RF magnetic stand, RP-SMA (male) to RP-SMA (female), RG-174/U cable, 1.5 m |
| A-CRF-RMNM-L1-300 | N-type (male) to RP SMA (male), LMR-195 Lite cable, 3 m |
| A-CRF-RMNM-L1-900 | N-type (male) to RP SMA (male), LMR-195 Lite cable, 9 m |
| A-CRF-RMNM-L1-600 | N-type (male) to RP SMA (male), LMR-195 Lite cable, 6 m |
| CRF-N0117SA-3M | N-type (male) to RP SMA (male), CFD200 cable, 3 m |
| A-CRF-RFRM-S2-60 | SS402 cable, RP-SMA (male) to RP-SMA (female) |

Surge Arrestors

| | |
|--------------|--|
| A-SA-NFNF-01 | Surge arrestor, N-type (female) to N-type (female) |
| A-SA-NMNF-01 | Surge arrestor, N-type (female) to N-type (male) |

Wireless Terminating Resistors

| | |
|-------------|--|
| A-TRM-50-RM | Termination resistor, 50 ohms, N-type male |
|-------------|--|

Wall-Mounting Kits

| | |
|----------|---|
| WK-51-01 | Wall-mounting kit, 2 plates, 6 screws, 51.6 x 67 x 2 mm |
|----------|---|

© Moxa Inc. All rights reserved. Updated Jun 12, 2019.

This document and any portion thereof may not be reproduced or used in any manner whatsoever without the express written permission of Moxa Inc. Product specifications subject to change without notice. Visit our website for the most up-to-date product information.